

BM4TFE

Mechanical Fixed Flange & Rotational Leveling Tool

Weights & Dimensions

- ✓ Tool weight: 8.6 kg
- ✓ Case weight: 2.5 kg
- ✓ Gross weight: 12.2 kg
- ✓ Molding Case Dimensions:
600 mm x 370 mm x 200 mm
- ✓ Aligning Force (With 68Nm of Torque Applied): 4 Ton

Range of Application

ASME	150#	10"-34"
	300#	8"-14" & 26"-36"
	400#	3½"-10" & 26"-36"
	600#	3½"-8" & 26"-36"
	900#	1"-3" & 4"-6"
	1500#	1¼"-3"
	2500#	1"-2½"

Kit Components

- ✓ 1 x BM4TFE Tool
- ✓ 1 x 68N·m Torque Wrench
- ✓ 1 x 22mm Socket
- ✓ 1 x Ratchet Strap
- ✓ 1 x Molding Case

Designed for different industries



Minimum Extension

Maximum Extension

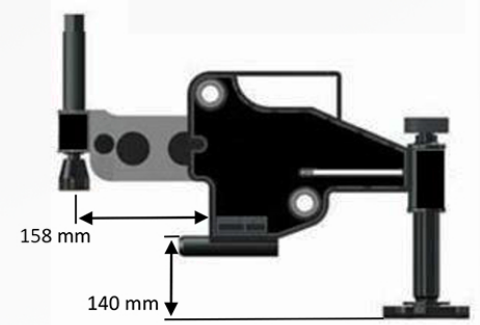
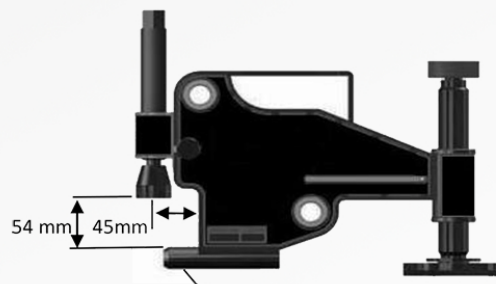
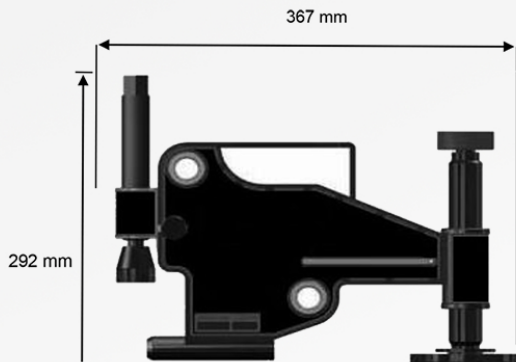

Minimum applicable Bolt Hole Diameter 25mm (1.0")

SCAN ME



Tel: +65 6271 0800
Fax: +65 6273 3121
enquiries@petracarbon.com
www.petracarbon.com

