

BG SERIES

Shear Wrench

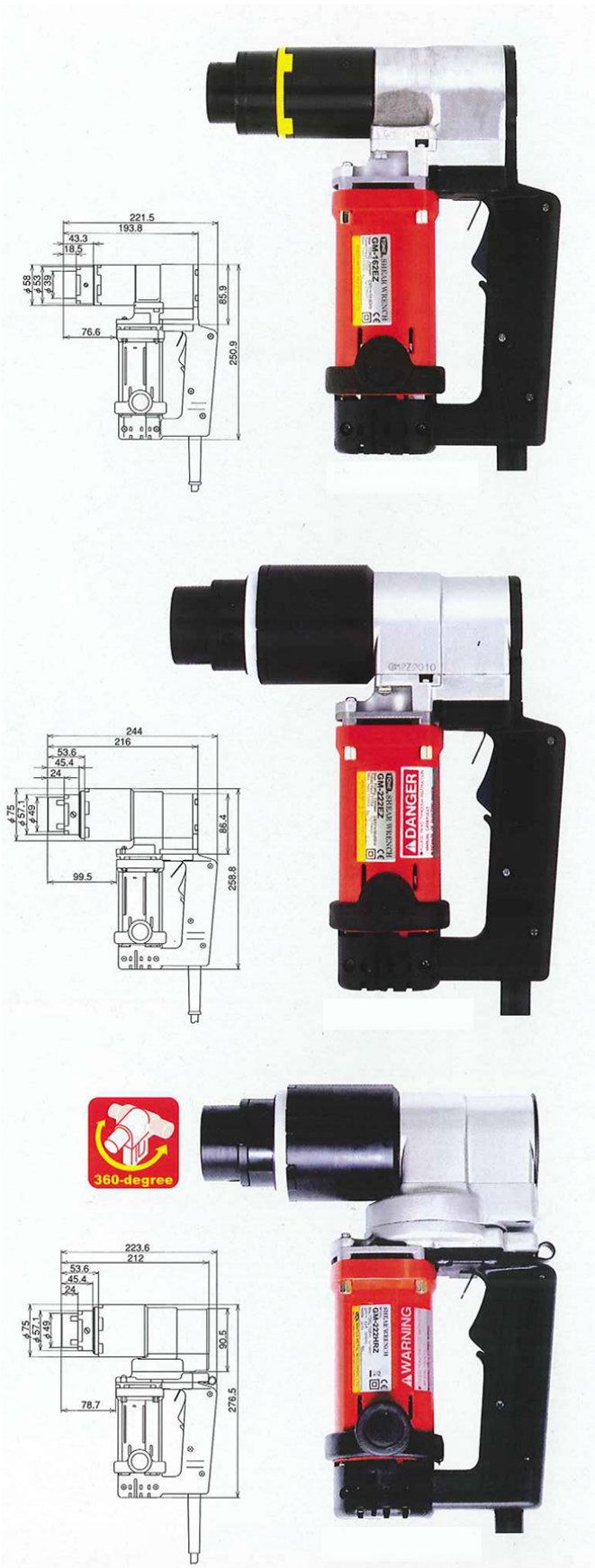

| Model | BGM-161EZ | BGM-162EZ |
|---|------------------------------|-----------|
| Frequency | 50-60Hz | |
| Rated Voltage (Single Phase) | 115V | 230V |
| Max. Current | 10A | 5A |
| Rated Input Power | 1100W | |
| Intermittent Operation (Rated Operating Time/ Rated Resting Time) | 2s/3s | |
| Rated Max. Torque | 294N.m (217 lbf.ft) | |
| No-Load Speed | 29min -1 (rpm) | |
| Sound Pressure Level | 87dB (A) | |
| Acoustic Power Level | 98dB (A) | |
| Vibration Level | 2.5m/s ² or below | |
| Adaptable Bolts Dia. | S10T | M12,M16 |
| | A325 | 5/8" |
| | A490 | 5/8" |
| Weight (Main Body) | 3.7kg (8.1lbs) | |
| Protection Class | Class II tool | |

| Model | BGM-221EZ | BGM-222EZ |
|---|------------------------------|------------------|
| Frequency | 50-60Hz | |
| Rated Voltage (Single Phase) | 115V | 230V |
| Max. Current | 11A | 5.5A |
| Rated Input Power | 1200W | |
| Intermittent Operation (Rated Operating Time/ Rated Resting Time) | 2s/3s | |
| Rated Max. Torque | 735N.m (542 lbf.ft) | |
| No-Load Speed | 14min -1 (rpm) | |
| Sound Pressure Level | 87dB (A) | |
| Acoustic Power Level | 98dB (A) | |
| Vibration Level | 2.5m/s ² or below | |
| Adaptable Bolts Dia. | S10T | M16,M20,M22 |
| | A325 | 5/8", 3/4", 7/8" |
| | A490 | 5/8", 3/4" |
| Weight (Main Body) | 4.8kg (10.6lbs) | |
| Protection Class | Class II tool | |

| Model | BGM-221HRZ | BGM-222HRZ |
|---|------------------------------|------------------|
| Frequency | 50-60Hz | |
| Rated Voltage (Single Phase) | 115V | 230V |
| Max. Current | 13A | 6.5A |
| Rated Input Power | 1400W | |
| Intermittent Operation (Rated Operating Time/ Rated Resting Time) | 2s/3s | |
| Rated Max. Torque | 735N.m (542 lbf.ft) | |
| No-Load Speed | 18min -1 (rpm) | |
| Sound Pressure Level | 87dB (A) | |
| Acoustic Power Level | 98dB (A) | |
| Vibration Level | 2.5m/s ² or below | |
| Adaptable Bolts Dia. | S10T | M16,M20,M22 |
| | A325 | 5/8", 3/4", 7/8" |
| | A490 | 5/8", 3/4" |
| Weight (Main Body) | 5.8kg (12.8lbs) | |
| Protection Class | Class II tool | |

SCAN ME



BG SERIES

Shear Wrench

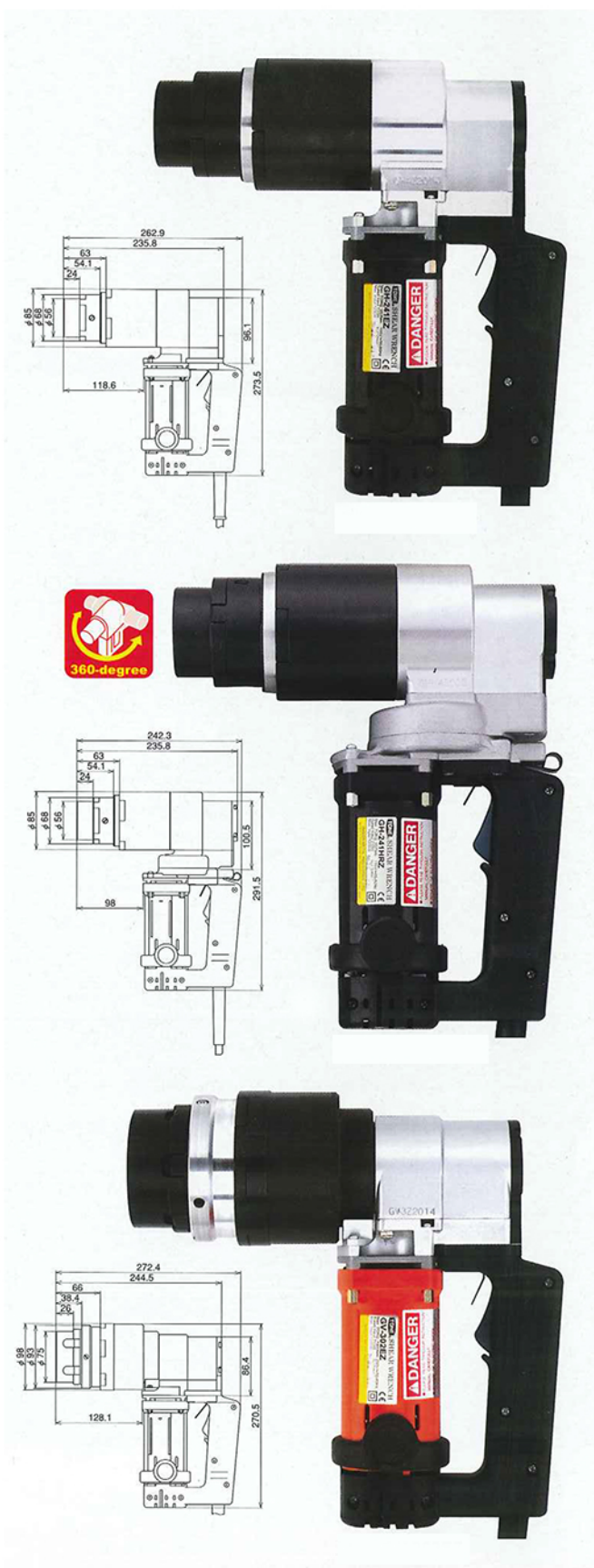

| Model | BGH-241EZ | BGH-242EZ |
|---|------------------------------|------------------|
| Frequency | 50-60Hz | |
| Rated Voltage (Single Phase) | 115V | 230V |
| Max. Current | 11A | 5.5A |
| Rated Input Power | 1200W | |
| Intermittent Operation (Rated Operating Time/ Rated Resting Time) | 2s/3s | |
| Rated Max. Torque | 950N.m (701 lbf.ft) | |
| No-Load Speed | 10min -1 (rpm) | |
| Sound Pressure Level | 87dB (A) | |
| Acoustic Power Level | 98dB (A) | |
| Vibration Level | 2.5m/s ² or below | |
| Adaptable Bolts Dia. | S10T | M16,M20,M22, M24 |
| | A325 | 5/8", 7/8", 1" |
| | A490 | 3/4", 7/8" |
| | Weight (Main Body) | 6.2kg (13.7lbs) |
| Protection Class | Class II tool | |

| Model | BGH-241HRZ | BGH-242HRZ |
|---|------------------------------|------------------|
| Frequency | 50-60Hz | |
| Rated Voltage (Single Phase) | 115V | 230V |
| Max. Current | 11A | 5.5A |
| Rated Input Power | 1200W | |
| Intermittent Operation (Rated Operating Time/ Rated Resting Time) | 2s/3s | |
| Rated Max. Torque | 950N.m (701 lbf.ft) | |
| No-Load Speed | 9min -1 (rpm) | |
| Sound Pressure Level | 87dB (A) | |
| Acoustic Power Level | 98dB (A) | |
| Vibration Level | 2.5m/s ² or below | |
| Adaptable Bolts Dia. | S10T | M16,M20,M22, M24 |
| | A325 | 3/4", 7/8", 1" |
| | A490 | 3/4", 7/8" |
| | Weight (Main Body) | 7.2kg (15.8lbs) |
| Protection Class | Class II tool | |

| Model | BGV-301EZ | BGV-302EZ |
|---|------------------------------|-----------------|
| Frequency | 50-60Hz | |
| Rated Voltage (Single Phase) | 115V | 230V |
| Max. Current | 11A | 5.5A |
| Rated Input Power | 1200W | |
| Intermittent Operation (Rated Operating Time/ Rated Resting Time) | 2s/3s | |
| Rated Max. Torque | 1900N.m (1402 lbf.ft) | |
| No-Load Speed | 5min -1 (rpm) | |
| Sound Pressure Level | 87dB (A) | |
| Acoustic Power Level | 98dB (A) | |
| Vibration Level | 2.5m/s ² or below | |
| Adaptable Bolts Dia. | S10T | M27,M30 |
| | A325 | 1-1/8" |
| | A490 | 1-1/8" |
| | Weight (Main Body) | 6.7kg (14.8lbs) |
| Protection Class | Class II tool | |

SCAN ME

