

COLD PIPE CUTTER

Operational Benefits

- ✓ **Low Profile Split-Frame Design**
Minimum operating clearance needed
- ✓ **Reliable**
Unique bearing system improves machine life
- ✓ **Robust and Durable**
Designed for heavy-duty applications
- ✓ **Quick and Easy**
Fast setup and operation with minimum time and effort
- ✓ **Quality and Safe**
Non-flammable, suitable under any hazardous conditions
- ✓ **Cutting Capability**
Severing (parting off), beveling, facing and boring
- ✓ **Cutting Ranges**
From 2" to 54"

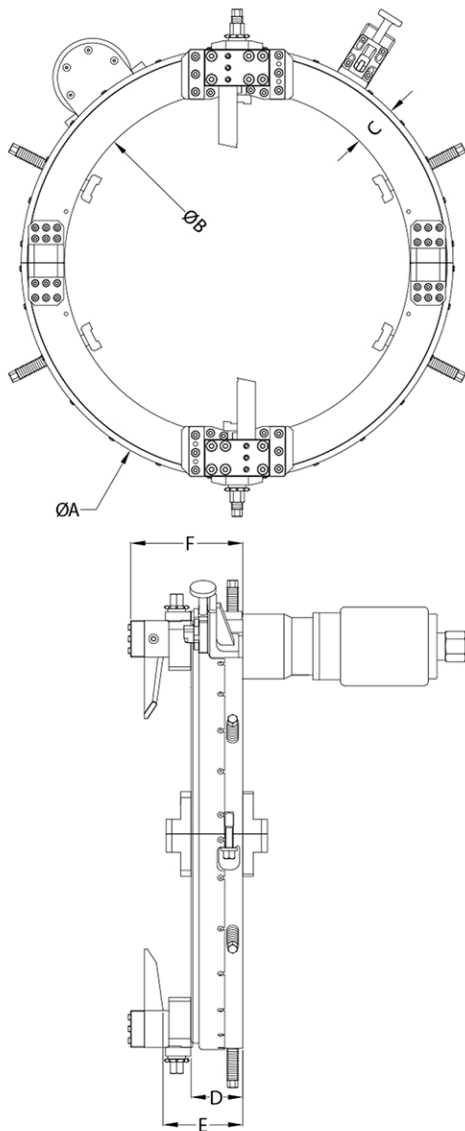

Technical Specifications

Model	Cutting Range		Tool Dimensions (mm)					
	inch		A	B	C	D	E	F
Jupiter Ext 2.4	2'-4"		245	127	59	71	109	163
Jupiter Ext 4.6	4'-6"		298	180	59	71	109	163
Jupiter Ext 8.12	8'-12"		454	336	59	71	109	163
Jupiter Ext 14.18	14'-18"		590	472	59	71	109	163
Jupiter Ext 18.24	18'-24"		760	630	65	79	117	171
Jupiter Ext 26.32	26'-32"		940	810	65	79	117	171
Jupiter Ext 26.32 MD	26'-32"		980	830	75	97	135	217
Jupiter Ext 30.36	30'-36"		1065	935	65	79	117	171
Jupiter Ext 30.36 HD	30'-36"		1143	935	104	127	165	254
Jupiter Ext 36.39	36'-39"		1140	1010	65	79	117	171
Jupiter Ext 38.46 MD	38'-46"		1346	1196	75	97	135	217
Jupiter Ext 38.44 HD	38'-44"		1404	1196	104	127	165	254
Jupiter Ext 48.52 HD	48'-52"		1554	1350	102	127	165	254
Jupiter Ext 48.54 HD	48'-54"		1600	1396	102	127	165	254

Cutter Travel: 25-152mm / Air Motor: 3.5HP / Air Flow: 90CFM / Optional: Hydraulic Drive (10HP)

Designed for different industries



SCAN ME



Tel: +65 6271 0800
 Fax: +65 6273 3121
enquiries@petracarbon.com
www.petracarbon.com

