

BSH15TP

Hydraulic Flange Spreader Wedge Twin Kit

Weights & Dimensions

- ✓ Tool weight: 7.0 kg
- ✓ Safety block: 0.38 kg
- ✓ Gross weight: 20.53 kg
- ✓ Packaging Dimensions:
580 mm x 340 mm x 180 mm

Designed for different industries



Spreading Force

With 700 bar (10,000 psi) hydraulic pressure applied
15.5 Ton per tool
It is recommended that tools are used in pair giving
2 x 15.5 Ton = 31 Ton

Kit Components

- ✓ 2 x Wedgehead
- ✓ 2 x 700 bar (10,000 psi) Hydraulic Cylinder
- ✓ 2 x Safety Block
- ✓ 2 x Pairs of Stepped Blocks
- ✓ 2 x Hex Key
- ✓ 1 x Molding Case



Tool Dimensions - Closed

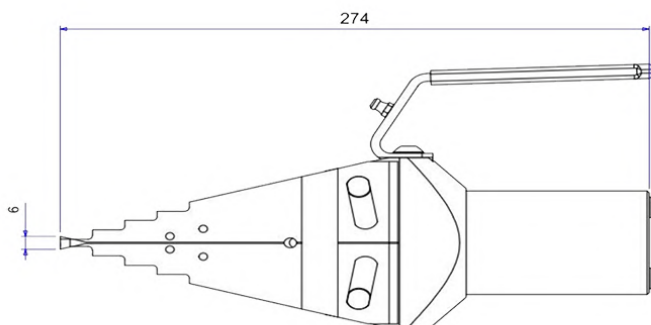

Tool Dimensions - Open

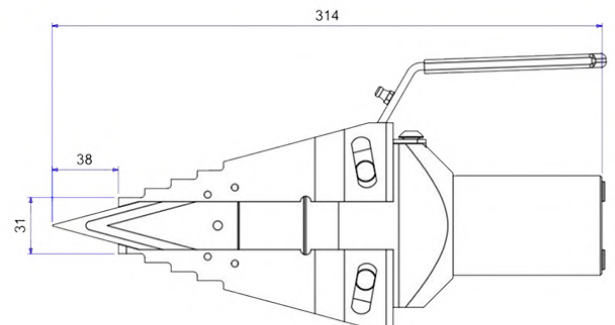

SCAN ME



Tel: +65 6271 0800
Fax: +65 6273 3121
enquiries@petracarbon.com
www.petracarbon.com



bizSAFE₃

BSH15TP

Hydraulic Flange Spreader Wedge Twin Kit

Range of Application

All flanges with a minimum access gap of 6 mm

Item No.	Part No.	Description	Quantity
1	C9311	Main Body	1
2	RC201HU	Cylinder	1
3	E8702	Push Pin	1
4	C0411	Wedge	1
5	F2930	Forged Jaw	2
6	E7702	Slide Pin	4
7	H8400	Screw	4
8	H1730	Grease Fitting	1
9	H0730	Screw	1
10	H2730	Screw	1
11	C3451	Handle	1
12	G1560	Handle Sleeve	1
13	G4560	White Plastic Cap	2
14	I9010	Roll Pin	8
15	M2010	Split Ring	1

*Items 6, 7, 9, 10 & 14 are supplied in Service Kit A

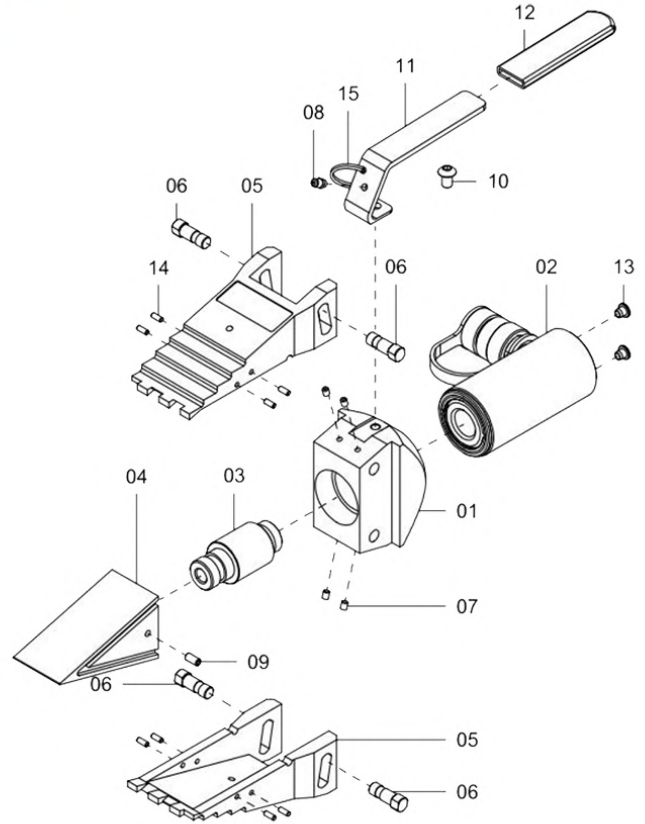

Tool Dimensions - Closed

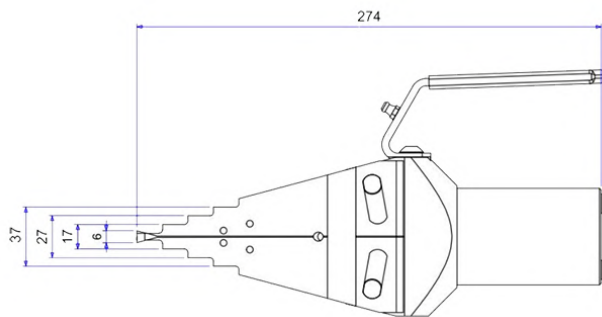

Tool Dimensions - Open

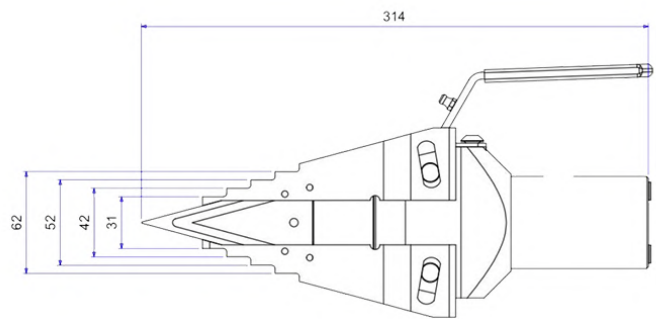

Safety Block (Part No. B1095) Dimensions

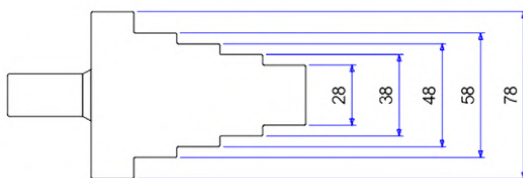

Stepped Blocks Part No. SBM62

Stepped Blocks can be used individually or in pairs to increase the max. spreading distance of the BSH15TP to 81 mm

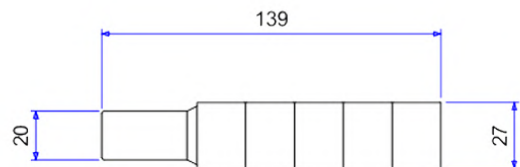

Weights and Dimensions
Stepped Block 0.52 kg

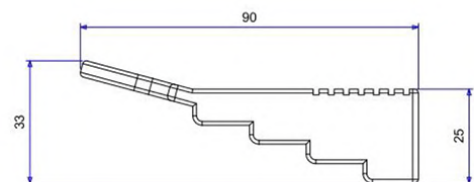

SCAN ME

