

BSM7T

Mini-Gap Flange Spreader

Weights & Dimensions

- ✓ Tool Weight: 5.0 kg
- ✓ Gross Kit Weight: 5.5 kg
- ✓ Carry-Case Dimensions: 360 x 300 x 90 mm

Spreading Force

6.8 Ton per tool

It is recommended that tools are used in pairs giving:

13.6 Ton

SPREADING DISTANCE: **2.0 mm - 27.0 mm**

Range of Application

By Flange Type, Class, Diameter

ASME B16.5
Weld Neck

2" through 48" for the flange class 150
3/4" through 48" for the flange class 300

ASME B16.5
Socket Welded

2" through 3" for the flange class 150
3/4" through 3" for the flange class 300

BS10

Class H: 1/2" through 24"

Class J: 1/2" through 24"

Class K: 1/2" through 20"

Class R: 1/2" through 20"

Class S: 1/2" through 16"

Class T: 1/2" through 13"

Kit Components

- ✓ 1 x BSM7T Tool
- ✓ 2 x Spreading Bar
- ✓ 1 x Carry Case



ANSI Reducing Flange
Including Threaded and Slip On Flange

2" through 48" for the flange class 150
3/4" through 48" for the flange class 300

ANSI Orifice Flange
Including Weld, Neck, Threaded and Slip On Flange

2" through 48" for the flange class 150
3/4" through 48" for the flange class 300

Designed for different industries

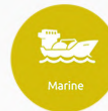

SCAN ME



Tel: +65 6271 0800
Fax: +65 6273 3121
enquiries@petracarbon.com
www.petracarbon.com



BSM7T

Mini-Gap Flange Spreader

Large Ø 20 mm spreading bar

TOOL CONFIGURATION 1
Retracted wedge

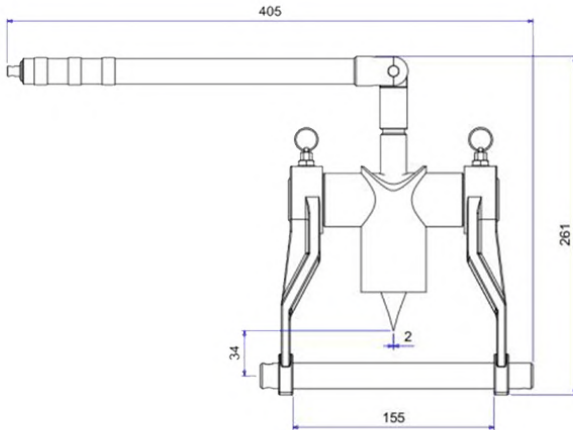

TOOL CONFIGURATION 1
Advanced wedge

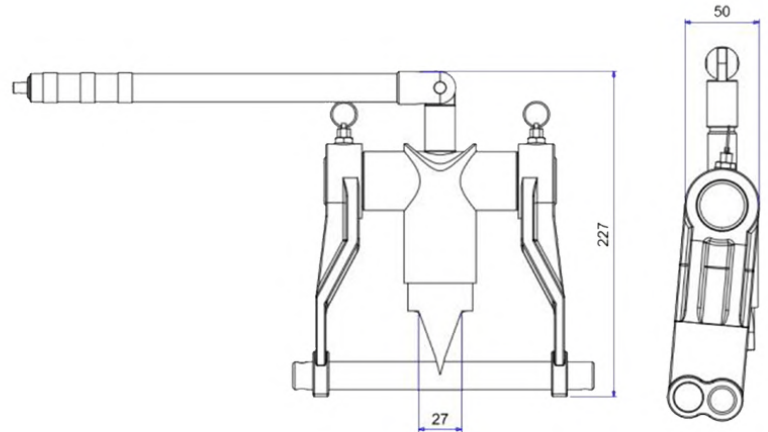

Small Ø 16 mm spreading bar

TOOL CONFIGURATION 2
Retracted wedge

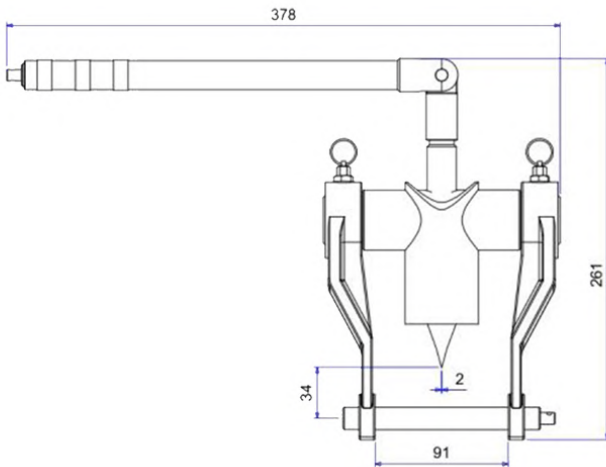

TOOL CONFIGURATION 2
Advanced wedge

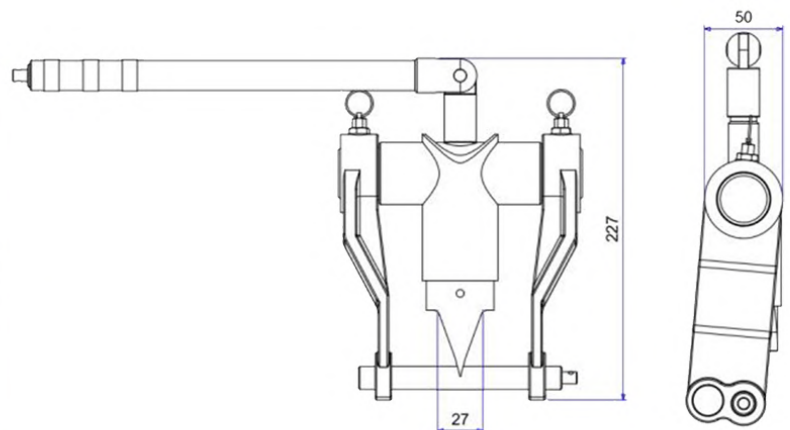

SCAN ME

