

BSM9T

Mechanical Flange Spreader Wedge Single Kit

Weights & Dimensions

- ✓ Tool Weight: 5.8 kg
- ✓ Torque Wrench: 1.5 kg
- ✓ Safety Block: 0.38 kg
- ✓ Pair of Stepped Blocks: 1.05 kg
- Packaging Dimensions::
- ✓ 580 mm x 340 mm x 180 mm / BSM9TM
- ✓ 190 mm x 180 mm x 320 mm / BSM9T

Kit Components

Product Code:	BSM9T	BSM9TM
Wedgehead	✓	✓
203 N·m (150 ft·lb) Torque Wrench with 22 mm socket	✓	✓
Safety Block	✓	✓
Pair of Stepped Blocks	✓	✓
Hex Key	✓	✓
Molding case	✓	✓
Carton Packaging	✓	
Gross Weight	9.24 kg	11.70 kg

Spreading Force

With 203 N. m of torque applied
9.4 Ton
 It is recommended that tools are used in pair giving
2 x 9.4 Ton = 18.8 Ton



Tool Dimensions - Closed

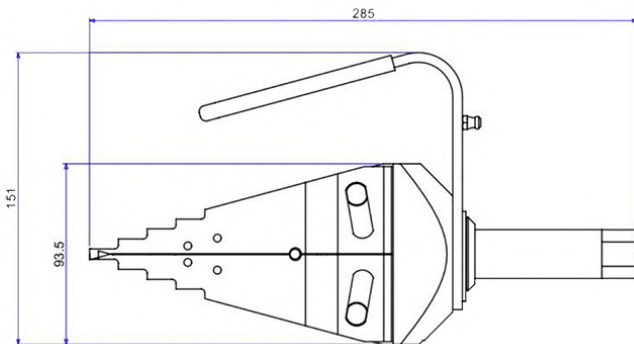

Tool Dimensions - Open

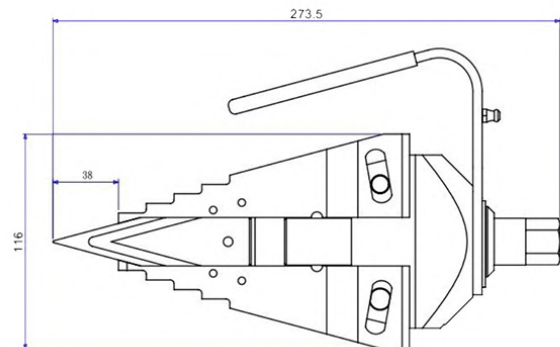

Designed for different industries



SCAN ME



Tel: +65 6271 0800
 Fax: +65 6273 3121
enquiries@petracarbon.com
www.petracarbon.com



BSM9T

Mechanical Flange Spreader Wedge Single Kit

Range of Application

All flanges with a minimum access gap of 6 mm

Item No.	Part No.	Description	Quantity
1	C9311	Main Body	1
2	E5702	Adaptor	1
3	E6702	Thrust Bearing Carrier	1
4	K6500	Bearing Set	1
5	H8400	Screw	4
6	G4560	White Plastic Cap	1
7	C1411	Handle	1
8	G1560	Handle Sleeve	1
9	I4400	Snap Ring	1
10	E1191	Push Rod	1
11	H8730	Nut	1
12	C0411	Wedge	1
13	H0730	Screw	1
14	F2930	Forged Jaw	2
15	E7702	Slide Pin	4
16	I9010	Roll Pin	8
17	H1730	Grease Fitting	1
18	M2010	Split Ring	1
19	TW210	Torque Wrench	1

*Items 4, 5, 11, 13 & 15 are supplied in Service Kit A
*Items 3 & 10 are supplied in Service Kit B

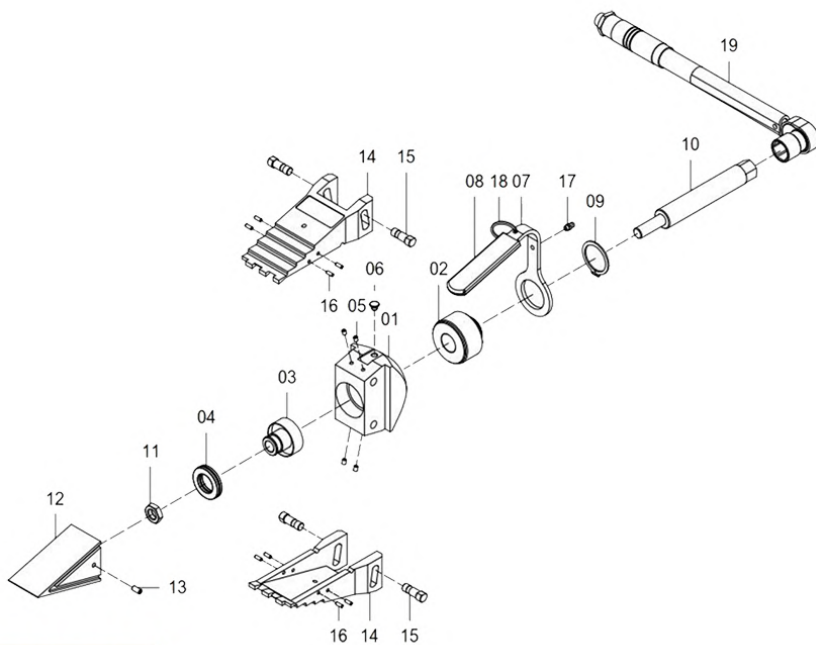

Tool Dimensions - Closed

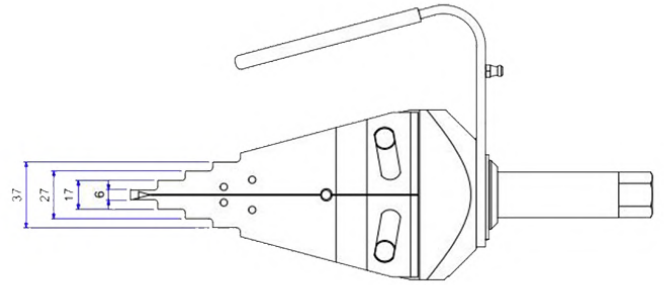

Tool Dimensions - Open

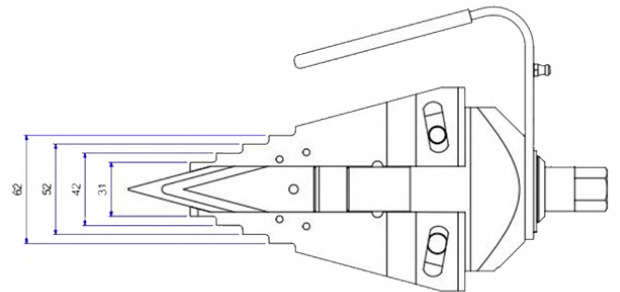

Safety Block (Part No. B1095) Dimensions

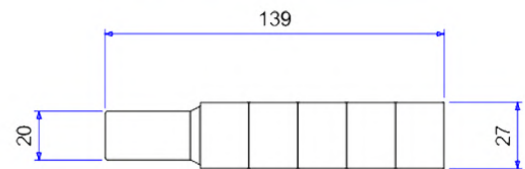
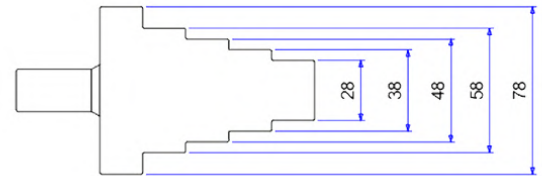

Weights and Dimensions
Stepped Block 0.52 kg

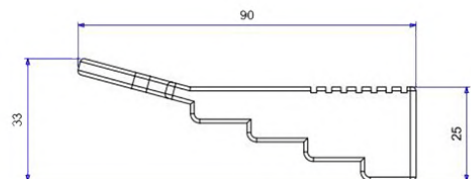

Stepped Blocks Part No. SBM62

Stepped Blocks can be used individually or in pairs to increase the max. spreading distance of the BSH15T to 81 mm



SCAN ME

